

SWV60400 Series

4 Channels Digital Video Optic Transceiver

Features

1. 8-bit digitally encoded and non-compression broadcast quality video transmission
2. Directly compatible with NTSC, PAL, and SECAM CCTV camera systems and support RS-232, RS-422, and RS-485 data protocols
3. Support any high-resolution video signal
4. Automatic compatible PAL, NTSC and SECAM video system
5. Power supply and other parameter state indication, which can monitor the operation condition of system
6. Support no-damage regenerative trunk of video
7. Constant input optical power, and large dynamic range ,no Electrical or Optical Adjustments Required .
8. Special ASIC design .
9. Industry-grade of operating temperature from -10°C to 65°C , which is applied to the different working environment
10. Hot-swap function
11. Stand-alone type or card-type installed in 19"4U rack-mount chassis.



Introduction

3onedata fiber-optic video transceivers SWV60400 series can simultaneously transmit 4 channels of 8-bit digitally encoded broadcast quality video/return or bidirectional data/unidirectional or bidirectional audio/Ethernet/Telephone/Dry contact over one multimode or single-mode optical fiber. These multiplexers are typically used in applications where the cameras have P/T/Z

capabilities. Plug and Play design ensures the ease of installation and operation. Electronic and optical adjustments are never required. LED indicators are provided for instantly monitoring system status. Devices are available for either standalone or rack-mount installation, which is suitable for different working environment.

Specification

Technical Specification

Video channels: **4 channels**

Video bandwidth: 8 MHz

Automatic compatible video system: PAL, NTSC, SECAM

Video input/output impedance: 75 Ω(unbalance)

Video signal-to-noise ratio: ≥67dB

Differential gain: (10%-90%APL) DG <1% (typical value)

Differential phase: (10%-90%APL) DP <0.7° (typical value)

Video connector: BNC

Fiber-optic Specification

F/O connector: FC/ST/SC

TX : Power:-15 ~ -8dBm Sensitivity :≤-35dBm

RX: Power:-15 ~ -8dBm Sensitivity :≤-35dBm

Optical Power Budget: 21dB

Transmission Distance :2 KM (Multi mode),20KM (single mode)

Operating Wavelength: TX1310/RX1550nm (Transmitter);

TX1550/RX1310nm (Receiver)

Specification of custom-made options

1. Data

Connector: Terminal Blocks

Encoded type : RS485 / RS422 / RS232 / Manchester

Data rate : 0 - 400Kbps

BER: ≤10⁻⁹

2. Audio

Connector: Terminal Blocks

Audio input / output impedance :600Ω(Balance/ unbalance)

Audio input / output voltage :2Vp-p (typical value)

Audio input / output level :0dBm (typical value)

Video bandwidth:10HZ~12KHZ

Audio digital encoded bandwidth :24bit

Audio signal-to-noise ratio: S/N≥95dB (weighted)

3. Telephone

Connector: RJ11

Bandwidth :8KHZ

Features: Support call-showing function ;support H-F

Operating mode : Point to point hotline mode / FXS-FXO

4. Ethernet

Connector: RJ45

Support mode : Half duplex or Full duplex

Standards: IEEE802.3

Data rate : 10M / 100Mbps

Bandwidth: 25M

Characteristic

Dimensions: 19.2(L)×17.3(W)×2.8(H) cm

Operating Voltage: DC5V (we will offer external power supply from AC96-240V to DC5V for each unit)

Operating Temperature: -10°C to +65°C

Storing Temperature: -45°C to +85°C

Humidity: 0 to 95% non-condensing

MTBF: ≥ 10⁵ hours

Warranty: 5 years

Approvals: FCC,CE, RoHS approvals

Application

1. Intelligent Transportation System
2. Connection of Sub-network for Surveillance Center
3. Public Security Surveillance
4. High Way & Toll Station Surveillance
5. Industrial Closed Circuit Television Surveillance

Packing List

1. SWV60400 series digital video optic transceiver×1
2. User manual ×1
3. 5VDC power adapter ×1(Media converter/5VDC, power external)

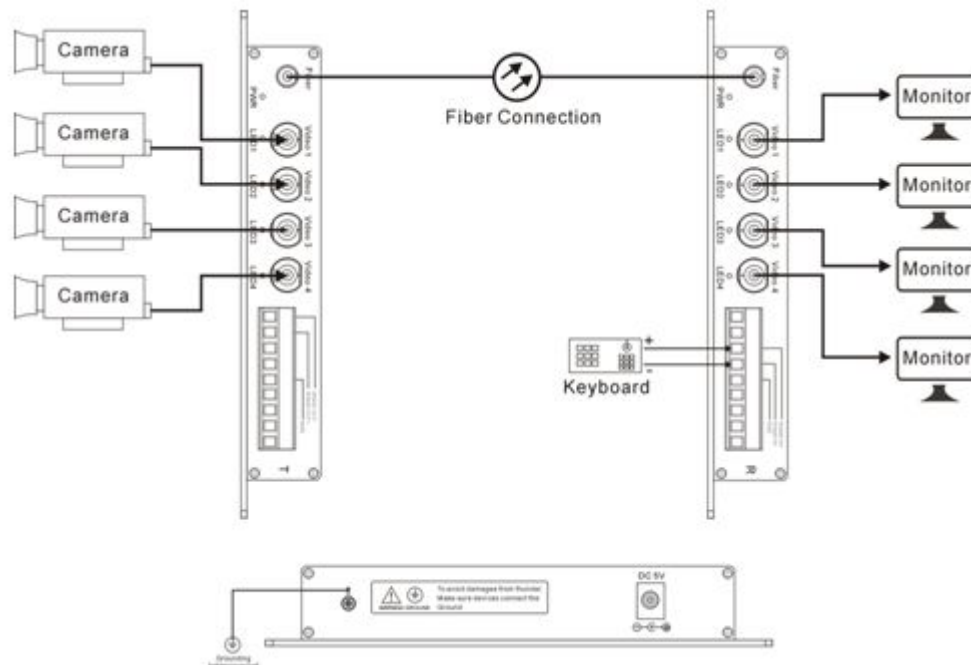

To install, connect the video inputs to the SWV60401-T, connect the video monitors or other video receptors to the SWV60401-R, and connect an appropriate optical fiber between the SWV60401-T and SWV60401-R optical ports. Connect data signal sources or destinations, as required, to the "DATA" port per the following Built-In Data Connection section.